



TEKTELIC Communications Inc.
7657 10th Street NE Calgary, Alberta
Canada, T2E 8X2

KONA HAZLOC MEGA GATEWAY

USER GUIDE

Document Number:	T0007531_UG
DOCUMENT ISSUE:	2.2
DOCUMENT STATUS:	RELEASED
PRODUCT CODES:	SEE TABLE
ISSUE DATE:	January 22, 2026

PROPRIETARY:

The information contained in this document is the property of TEKTELIC Communications Inc. Except as specifically authorized in writing by TEKTELIC, the holder of this document shall keep all information contained herein confidential, and shall protect the same in whole or in part from disclosure to all third parties.

© 2026 TEKTELIC Communications Inc., all rights reserved.

All products, names, and services are trademarks and registered trademarks of their respective companies.

TEKTELIC Communications Inc.
7657 10th Street NE
Calgary, AB, Canada T2E 8X2
Phone: (403) 338-6900

Table of Contents

Table of Contents.....	2
1 Product Description.....	3
1.1 Overview.....	3
1.2 Physical Interfaces	4
1.3 Specifications.....	6
1.4 Certifications.....	6
1.5 Exposed services	7
2 Installation	8
2.1 Safety Precautions	8
2.2 Unpacking and Inspection	9
2.3 Required Equipment for Installation.....	10
2.4 KONA HazLoc Mega Gateway Mounting.....	10
2.5 Ground Cable Installation	12
2.6 Direct DC Power Cable Installation	13
2.7 Copper Ethernet Cable Installation.....	14
2.8 LoRa RF Antenna Installation	14
2.9 GPS RF Antenna Installation	16
2.10 Cellular RF Antenna Installation.....	16
2.11 Proposition 65	16
3 Radio Compliance Statements.....	17
Revision History	20

1 Product Description

1.1 Overview

The KONA HazLoc Mega Gateway is an outdoor hardened Hazardous Location deployable LoRaWAN IoT gateway that supports the full range of LoRa WAN channels.

The Gateway features Zone 2, Zone 22, and Division 2 certification for hazardous Gas or Dust environments, an IP67 (Type 6) ingress protected enclosure, and built-in surge protection on all external interface ports (excluding the Cellular Antenna port).

The Gateway LoRa RF antenna ports are certified as intrinsically safe, allowing the use of cost-effective antennas assessed as simple apparatus.

The Gateway supports:

- one or two external LoRa antennas,
- one external GPS antenna,
- one external cellular antenna,
- one copper Ethernet port including Power over Ethernet (PoE), and
- one DC power port.

Table 1 lists the currently available KONA HazLoc Mega Gateway models.

Table 1: KONA HazLoc Mega Gateway Models

Model	Order Code	Cellular Modem	LoRa Antennas	Geolocation	Region	Channel Plan	Mode
T0007208		Yes	1	Yes	North America	US915	FDD
T0007209		Yes	1	Yes	Europe	EU868	TDD
T0007210		Yes	1	Yes	Australia	AU915	TDD
T0007211		Yes	1	Yes	Singapore	AS923	TDD
T0007212		Yes	1	Yes	Japan	AS923	TDD
T0007283	MAT32NUS915	Yes	2	Yes	North America	US915	FDD
T0007284	MAT32NEU868	Yes	2	Yes	Europe	EU868	TDD
T0007285		Yes	2	Yes	Australia	AU915	TDD
T0007286		Yes	2	Yes	Singapore	AS923	TDD
T0007287		Yes	2	Yes	Japan	AS923	TDD

Note: The second antenna port connector may or may not be present on the single antenna models.

Figure 1 illustrates the KONA HazLoc Mega Gateway. All models share the same mechanical form-factor.

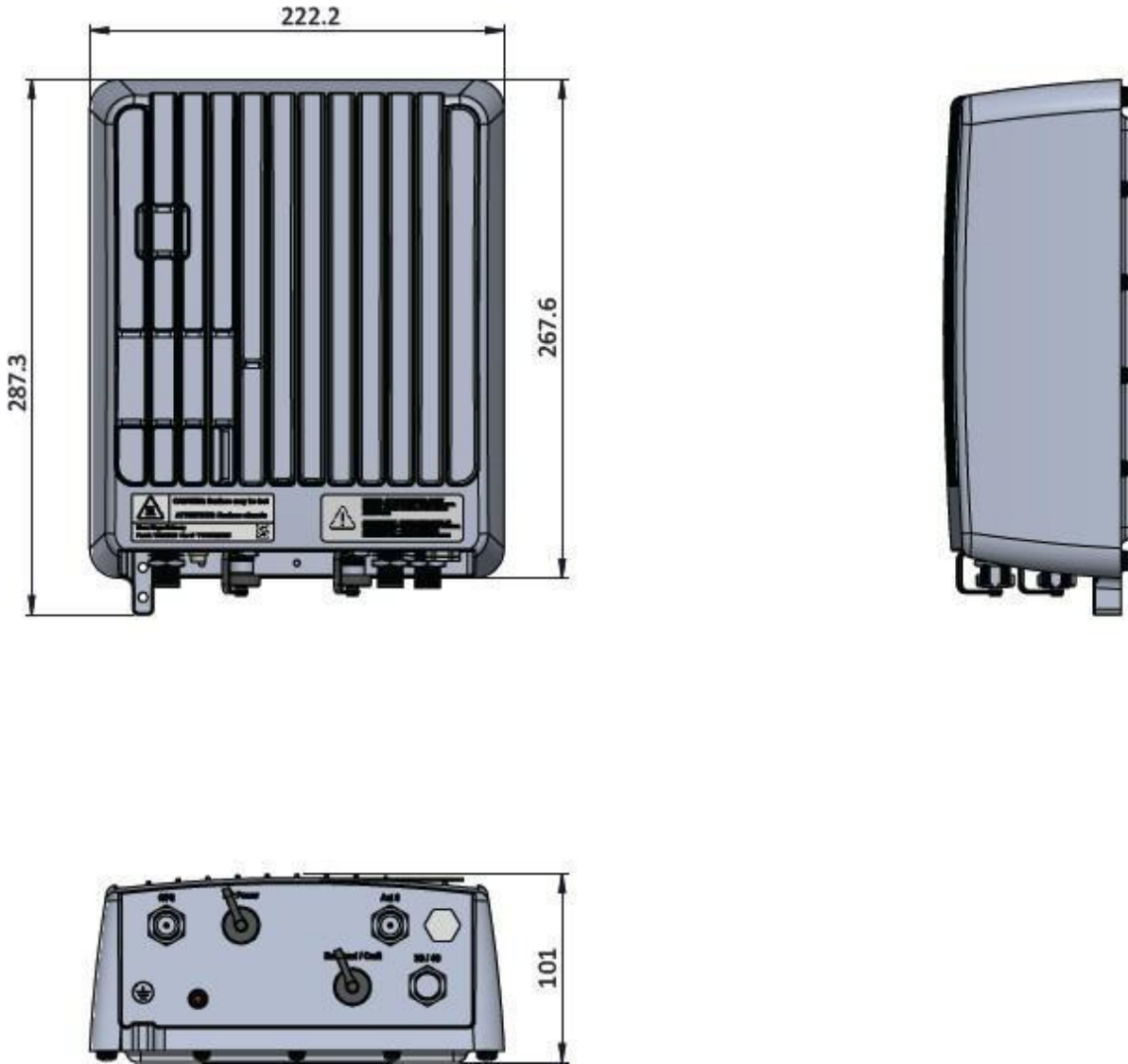

Figure 1: KONA HazLoc Mega Gateway

1.2 Physical Interfaces

Figure 2 details the bulkhead layout for the KONA HazLoc Mega Gateway.

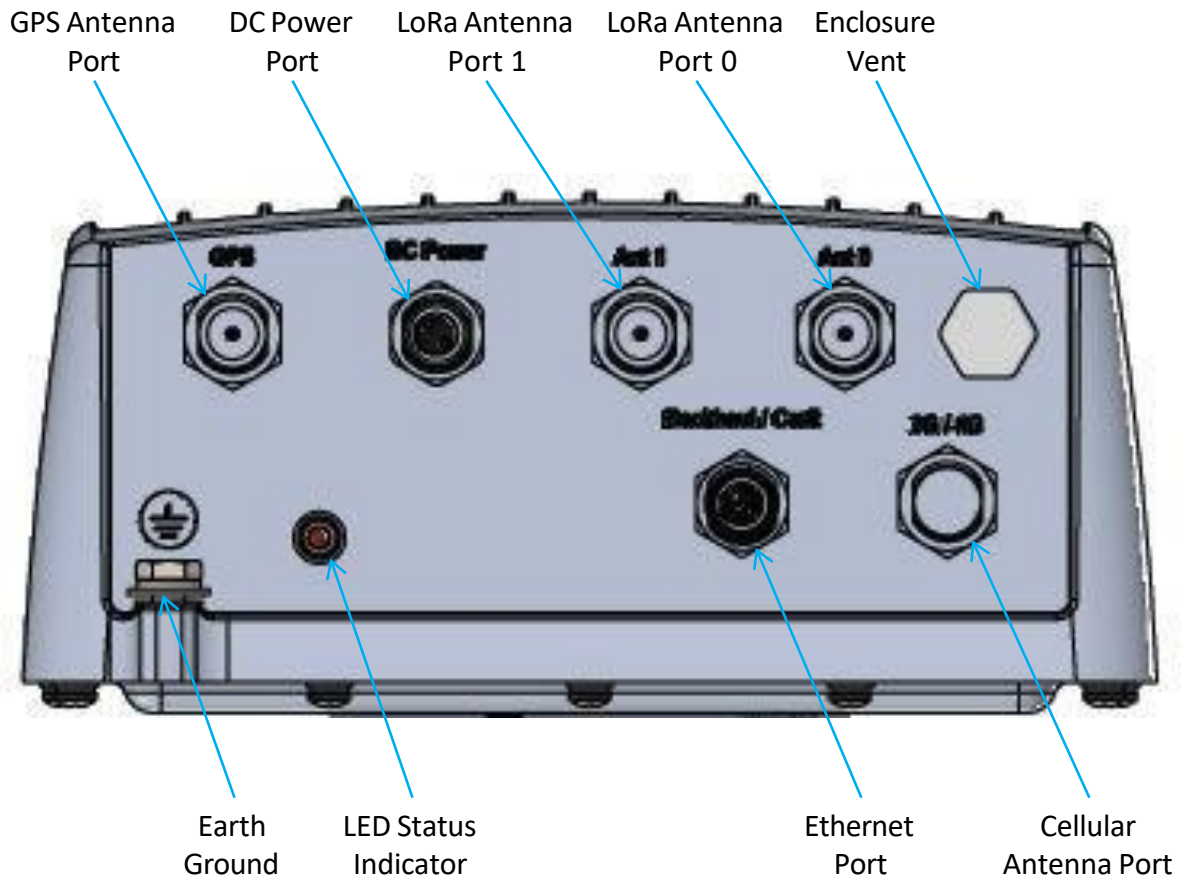

Figure 2: KONA HazLoc Mega Gateway Bulkhead Layout

Connector types and their mating connectors are listed in Table 2.

Table 2: KONA HazLoc Mega Gateway Interface Connector Types

Interface	Connector Type	Mating Connector
LoRa Antenna	N-Type female	Industry standard N-Type male Note: this port is certified as Intrinsically Safe
Cellular Antenna	N-Type female	Industry standard N-Type male
GPS Antenna	N-Type female	Industry standard N-Type male
Copper Ethernet	M12 male threaded, 8 contact, X-coded	TE Connectivity 2327989-1 or equivalent
DC Power Input	M12 male threaded 2 contact, A-coded	TE Connectivity T4111002021-000 or equivalent
Earth Ground	1/4 - 20 UNC double hole	Industry standard 2-hole lug, 1/4" x 0.63" spacing

1.3 Specifications

The KONA HazLoc Mega Gateway specifications are listed in Table 3.



Table 3: KONA HazLoc Mega Gateway Specifications



Attribute	Specification
Dimensions	222 mm (8.7") wide x 101 mm (4.0") deep x 267.6 mm (10.5") tall (Body only) 222 mm (8.7") wide x 101 mm (4.0") deep x 287 mm (11.3") tall (Total, including connectors)
Weight	5.4 kg (12 lbs)
Operating Temperature	-40°C to 60°C (-40°F to 140°F) at sea level Including solar loading
Relative Humidity	10% to 100%
Operating Altitude	-60 m to 4,000 m (-197 ft to 13,123 ft)
Power Input, Direct DC	48 Vdc nominal, 37 to 57 Vdc operating range (after 42 V maximum start-up threshold). Positive or negative ground referenced feed. SELV & LPS source required. Maximum 10A input overcurrent protection.
Power Input, PoE	IEEE 802.3 at Mode A or Mode B or 4-pair mode
Power Consumption	25 W maximum
GPS Power	5 V, 50 mA maximum
Surge Protection	All interfaces are protected to IEC 61000-4-5 Class 5 (except cellular antenna port)

1.4 Certifications

The KONA HazLoc Mega Gateway Certifications are listed in Table 4.

Table 4: KONA HazLoc Mega Gateway Certifications

Certification	Specifications	Marking
EMC	FCC Pt. 15 RSS-247 EN 301 489-1	FCC, IC, CE
IT Equipment	UL/CSA/EN/IEC 62368-1 UL/CSA/EN/IEC 60950-22	CE Type 6, IP-67 
CAN & USA Division	CSA C22.2 No. 213 UL 12.12.01: 2017	Class I, Div 2, Groups A, B, C, D, T5 Class II, Div 2, Groups F, G, T5 Certificate E518540 

CAN Zone	CSA C22.2 No. 60079-0 CSA C22.2 No. 60079-7 CSA C22.2 No. 60079-11 CSA C22.2 No. 60079-31	Class I Zone 2 Ex ec [ic] IIC T5 Gc Class II Zone 22 Ex tc [ic] IIIC T100°C Dc Certificate E518540
Certification	Specifications	Marking
USA Zone	UL 60079-0 UL 60079-7 UL 60079-11 UL 60079-31	Class I Zone 2 AEx ec [ic] IIC T5 Gc Class II Zone 22 AEx tc [ic] IIIC T100°C Dc Certificate E518540
IECEX	IEC 60079-0 IEC 60079-7 IEC 60079-11 IEC 60079-31	Ex ec [ic] IIC T5 Gc Ex tc [ic] IIIC T100°C Dc IP67 Certificate IECEX UL 21.0074X
ATEX	EN 60079-0 EN 60079-7 EN 60079-11 EN 60079-31	 II 3 G Ex ec [ic] IIC T5 Gc  II 3 D Ex tc [ic] IIIC T100°C Dc IP67 Certificate UL 21 ATEX 2477X
Temperature		-40 °C ≤ Ta ≤ +60 °C

1.5 Exposed services

The following services are exposed in factory default state:

- SSH (TCP port 22) – Provides secure command-line access to the equipment.
- SNMPv3 (UDP port 161) – Secure management and monitoring with encryption and authentication.
- mDNS (UDP port 5353) – Enables local service discovery, allowing the use of user-friendly domain names when addressing the equipment, limited to the local network scope.
- ICMP (Ping) – Basic connectivity and availability check.
- HTTPS (TCP port 443) – Provides secure access to the web management interface using TLS encryption.

2 Installation

2.1 Safety Precautions

Always use and save these instructions!

Warning - Explosion Hazard! Do not open the gateway enclosure in an explosive atmosphere. The KONA HazLoc Mega Gateway has no internal field serviceable parts. The Gateway module must only be opened at an approved TEKTELIC service center.

Warning - Explosion Hazard! The equipment shall only be used in an area of not more than pollution degree 2, as defined in IEC/EN 60664-1.

Avertissement - Risque d'explosion! L'équipement ne doit être utilisé que dans une zone ne dépassant pas le degré de pollution 2, tel que défini dans la norme IEC/EN 60664-1.

Warning - Explosion Hazard! Do not connect or disconnect when energized.

Avertissement - Risque d'explosion! Ne pas brancher ni débrancher sous tension.

Warning - Explosion Hazard! Do not connect or disconnect the DC input power cable or the Ethernet cable unless both cables have been de-energized by shutting off all power at the sources.

Warning - Explosion Hazard! Do not connect or disconnect the GPS antenna cable unless the Gateway has been de-energized by shutting off all power at the sources.

Warning - Explosion Hazard! The Gateway might have more than one power supply connection. All power sources must be shut off to de-energize the Gateway.

Warning - Explosion Hazard! The DC input power bulkhead connector and the Ethernet bulkhead connector must be terminated with the specified sealing mating connector. When not terminated, these bulkhead connectors must be protected with the tethered protective sealing caps.

Warning - Explosion Hazard! The Gateway Earth Ground connection must always be connected to a site earth ground point using a minimum 10 AWG (5 mm²) conductor.

Warning - Explosion Hazard! The KONA HazLoc Mega Gateway must always be mounted vertically with the bulkhead connector field facing down towards earth.

Warning - Explosion Hazard! The KONA HazLoc Mega Gateway RF antennas must be limited in gain. The LoRa antenna gain must not exceed 6 dBi. The cellular antenna gain must not exceed 2 dBi.

Warning - Explosion Hazard! The KONA HazLoc Mega Gateway installation must be in accordance with local and national electrical codes.

Warning - Do not locate the antenna near overhead power lines. Refer to national and local codes for proper antenna installation and grounding (for example, the U.S. National Electrical Code, NFPA 70, Article 810 or the Canadian Electrical Code, Section 54).

Warning - The KONA HazLoc Mega Gateway must be installed in a restricted access location (such that touching of the Gateway by non-service persons is not likely).

Warning - The KONA HazLoc Mega Gateway may become hot to the touch during normal operation at high ambient temperatures.

Warning - Do not work on the system during periods of lightning activity.

Warning - Ensure the KONA HazLoc Mega Gateway Earth Ground connection is properly terminated prior to the connection of any other interface.

Warning - The KONA HazLoc Mega Gateway contains primary lightning surge suppression on the DC input power port, the Copper Ethernet port, and the LoRa RF antenna port. The primary lightning protectors have the ability to conduct energy to chassis during over-voltages. Ensure that the Gateway Earth Ground connection is always in place.

Warning - Ensure that the KONA HazLoc Mega Gateway is secured to eliminate any physical hazard to people or property. The Gateway must be securely mounted according to the mounting instructions prior to any cable connection and operation.

Warning - The KONA HazLoc Mega Gateway power source must meet SELV and LPS safety requirements.

Caution - For the DC input power connector, the DC positive pin must be at positive potential relative to the DC negative pin. If the polarity is reversed, the unit will not sustain damage but will not operate until the connection polarity is corrected.

Caution - Although the KONA HazLoc Mega Gateway can be powered through either the direct DC input or the power over Ethernet (PoE) input, simultaneous application of power to both inputs may result in unexpected operation and should be avoided.

2.2 Unpacking and Inspection

The following should be considered during the unpacking of a new KONA HazLoc Mega Gateway.

1. Inspect the shipping carton and report any significant damage to TEKTELIC.
2. Unpacking should be conducted in a clean, dry, and non-hazardous location.
3. Do not discard the shipping box or foam inserts as they will be required if a unit is returned for repair or re-configuration.

2.3 Required Equipment for Installation

The following tools are required to install the KONA HazLoc Mega Gateway module:

1. A 6 point metric socket set and torque wrench drive.
2. Anti-oxidant compound (NO-OX-ID, Penetrox, Noalox, Ox-Gard or equivalent).
3. A small wire brush.
4. A clean cloth.
5. Weatherproofing tape kit for the RF connector (Scotch Wireless Weatherproofing Kit, WK-101 recommended).
6. Appropriately sized pipe clamps for pole mounting or appropriate screws or bolts (quantity four, size M8) with any required anchors according to the wall construction for wall mounting.

2.4 KONA HazLoc Mega Gateway Mounting

KONA HazLoc Mega Gateway is designed to be mounted to a vertical pole or wall using a mounting bracket. The mounting bracket is a single part that bolts to the back surface of the Gateway using supplied hardware (four M6x1.0 - 14 mm bolts with flat and star lock washers) as illustrated in [Figure 3](#). The Gateway module must be oriented with the connector bulkhead facing down, towards earth.

Ensure that the structure to which the Gateway is being mounted is secure and able to support a dead load of at least 136 kg (300 lbs). The area below must be free of any obstructions to cable ingress.

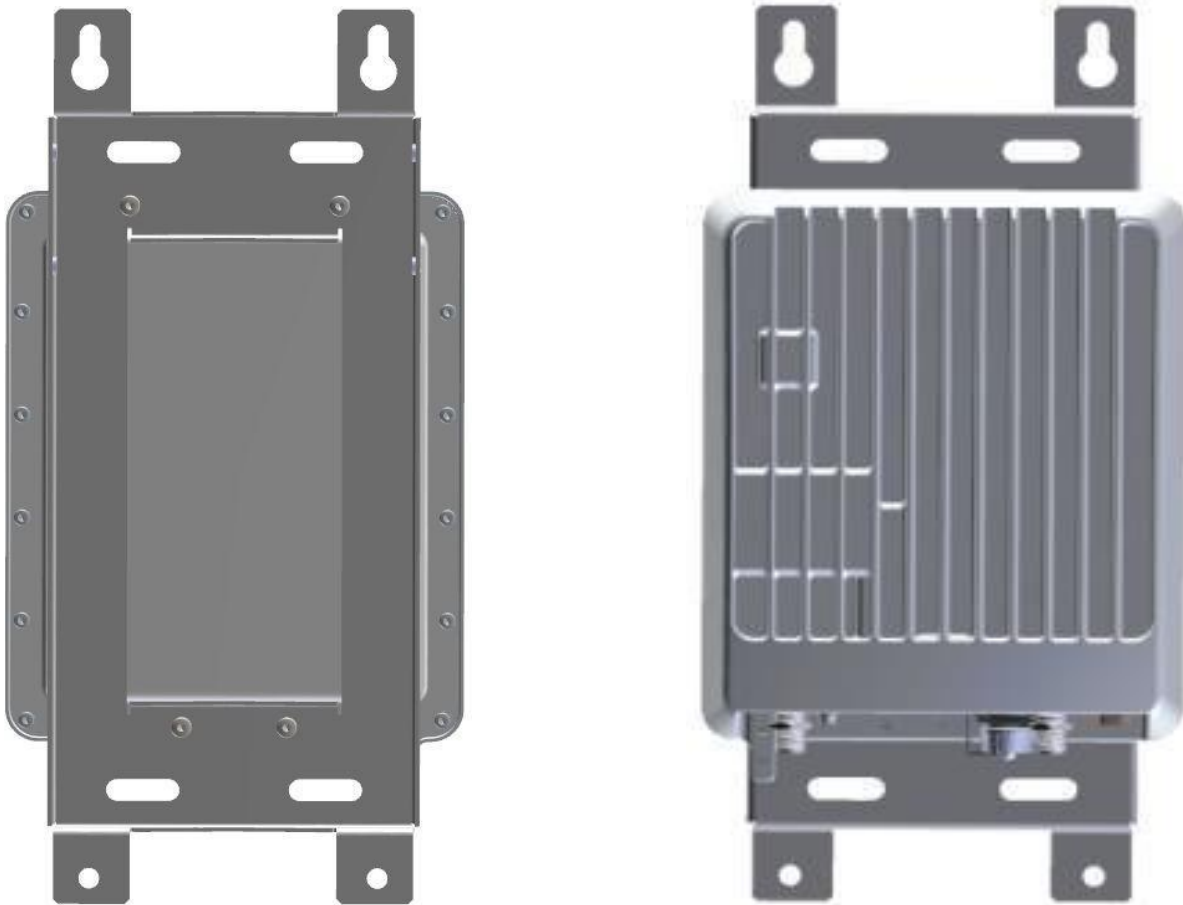

Figure 3: KONA HazLoc Gateway Module with Mounting Bracket

The KONA HazLoc Mega Gateway wall mounting procedure is as follows:

1. Bolt the wall mounting bracket to the Gateway module using the supplied bolts and washers.
2. Install 2 site supplied M8 bolts into the wall at 139.7 mm (5.5”) center spacing, leaving the bolt heads protruding with a 2mm gap from the wall surface.
3. Hang the Gateway module with bracket from the two bolts by inserting the keyhole slots at the top of the bracket onto the 2 bolts and tightening the bolts.
4. Insert and tighten two additional site supplied M8 bolts through the holes at the bottom of the bracket.

The KONA HazLoc Mega Gateway pole mounting procedure is as follows:

1. Bolt the wall mounting bracket to the Gateway module using the supplied bolts and washers.

2. While temporarily supporting the Gateway with bracket, install the two site supplied pipe clamps, one through each of the upper and lower slotted clamp mounting points.

2.5 Ground Cable Installation

The KONA HazLoc Mega Gateway requires a permanently connected Protective Earth (PE) Ground conductor. The Protective Earth Ground connection is made through a 1/4 x 0.63" on center double hole lug to the ground termination point illustrated in Figure 4. The required ground cable gauge is #10 AWG minimum.

The KONA HazLoc Mega Gateway grounding system shall follow local and national electrical codes. The Protective Earth Ground conductor terminated at the double hole lug point is mandatory and must be the first connection made to the KONA HazLoc Mega Gateway during installation. Proper routing and termination of this cable is key to robust lightning withstand performance; in high susceptibility installations, every effort shall be made to minimize connection inductance and ground bed resistance.

The ground cable installation steps are as follows:

1. Lightly abrade the surface of the casting ground area with a fine wire brush to remove the oxide layer.
2. Use a clean cloth to remove any debris from this surface.
3. Immediately coat the contact surface with a thin layer of anti-oxidant compound.
4. Install the ground cable through its 2-hole lug onto the chassis ground point using the two supplied 1/4 - 20 UNC x 1/2" long bolts with flat and star lock washers, torqued to 10.4 Nm (7.7 ft·lbs).

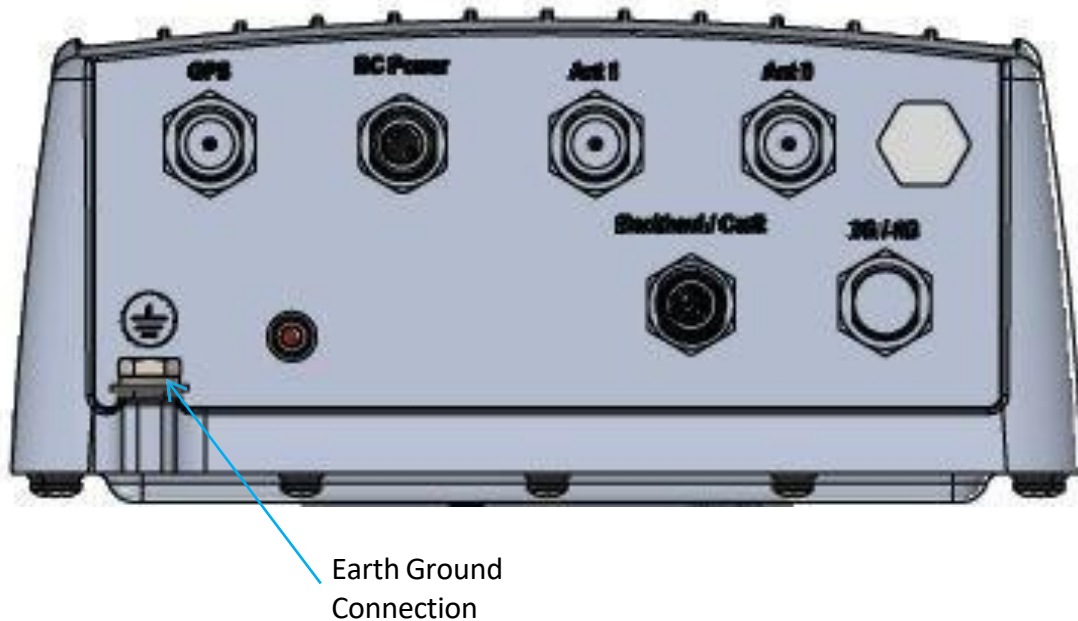

Figure 4: Earth Ground Connection Location

2.6 Direct DC Power Cable Installation

When direct DC powering is used, the proper water and dust tight mating connector specified in Table 2 must be used. The mating connector shall be assembled onto appropriate cable in accordance with the manufacturer's installation instructions.

The DC power cable shall be rated for outdoor application and shall be in accordance with national and local electrical codes.

The signal polarity identified in Figure 5 shall be followed for the DC power connector.

Torque the connector to 0.6 Nm (0.44 ft·lbs).

When the DC power connector is not in use, the tethered protective cap must be installed to maintain the required ingress protection.

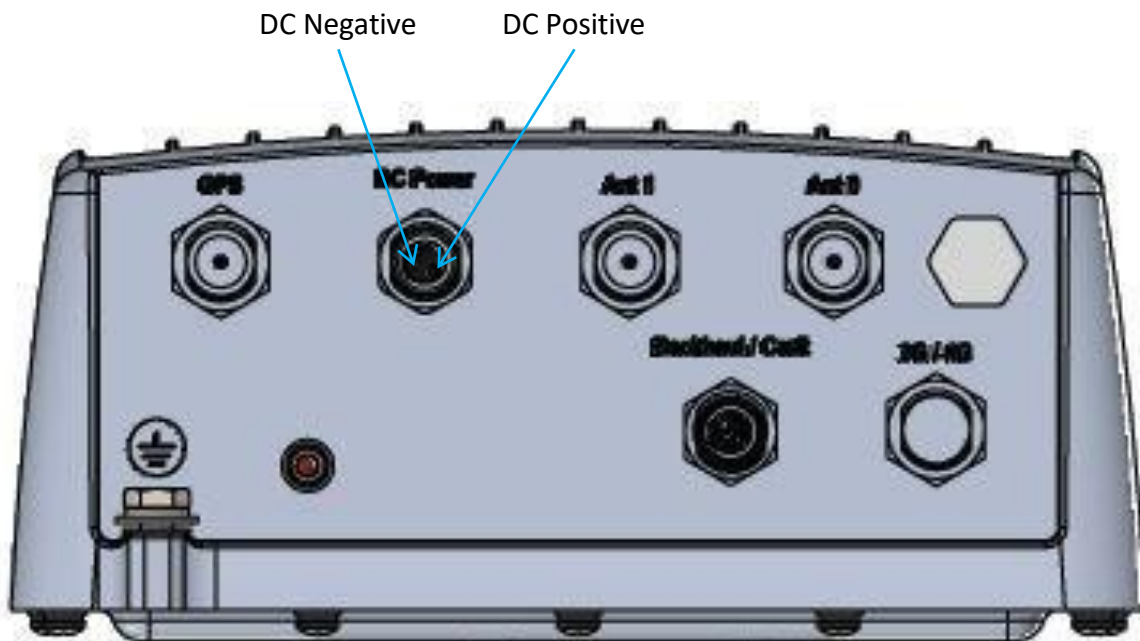

Figure 5: Direct DC Power Connector Polarity

2.7 Copper Ethernet Cable Installation

The KONA HazLoc Mega Gateway Ethernet port may be used on a temporary basis for commissioning and maintenance or may be permanently connected for backhaul and/or PoE powering.

When the Ethernet port is permanently connected, the proper water and dust tight mating connector specified in Table 2 must be used. The mating connector shall be assembled onto appropriate cable in accordance with the manufacturer's installation instructions.

The Ethernet cable shall be suitable for outdoor application and shall be in accordance with national and local electrical codes.

Torque the mating connector to 0.6 Nm (0.44 ft·lbs).

When the Ethernet connector is not in use, the tethered protective cap must be installed to maintain the required ingress protection.

2.8 LoRa RF Antenna Installation

The KONA HazLoc Mega Gateway supports connection to one or two LoRa RF antennas. The LoRa RF antenna attaches through a cable to an N-Type connector located on the bulkhead of the

Gateway. The LoRa RF connector shield is grounded to earth through the Gateway's Earth Ground connection.

Torque the Gateway RF connector to 1.7 to 2.3 Nm (1.3 to 1.7 ft·lbs).

The Gateway LoRa RF antenna connection is certified as intrinsically safe. This allows for the use, in the Gateway environment, of a standard antenna (TEKTELIC part number T0005535 or T0005194) illustrated in Figure 6.



Figure 6: LoRa RF Antenna

The LoRa antenna gain must be limited to 6 dBi.

The LoRa RF antenna bulkhead connector provides the required ingress protection for the Gateway even when it is unmated. Although the N-Type bulkhead connector on the Gateway provides ingress protection for the Gateway, the mating cable connector is likely not water proof and must be taped to provide ingress protection for the cable. TEKTELIC recommends taping with Scotch Wireless Weatherproofing Kit, WK-101. Follow the taping procedures outlined by the supplier of this tape system.

2.9 GPS RF Antenna Installation

The KONA HazLoc Mega Gateway supports connection to a GPS RF antenna. The GPS antenna attaches through a cable to the N-Type connector located on the bulkhead of the Gateway. The GPS RF connector shield is grounded to earth through the Gateway's Earth Ground connection.

Torque the Gateway RF connector to 1.7 to 2.3 Nm (1.3 to 1.7 ft·lbs).

The GPS antenna must have the required location certification.

The GPS RF antenna bulkhead connector provides the required ingress protection for the Gateway even when it is unmated. Although the N-Type bulkhead connector on the Gateway provides ingress protection for the Gateway, the mating cable connector is likely not water proof and must be taped to provide ingress protection for the cable. TEKTELIC recommends taping with Scotch Wireless Weatherproofing Kit, WK-101. Follow the taping procedures outlined by the supplier of this tape system.

2.10 Cellular RF Antenna Installation

The KONA HazLoc Mega Gateway supports connection to a cellular RF antenna. The cellular antenna attaches through a cable to the N-Type connector located on the bulkhead of the Gateway. The cellular RF connector shield is grounded to earth through the Gateway's Earth Ground connection.

Torque the Gateway RF connector to 1.7 to 2.3 Nm (1.3 to 1.7 ft·lbs).

The cellular antenna must have the required location certification.

The cellular antenna gain must be limited to 2 dBi.

The GPS RF antenna bulkhead connector provides the required ingress protection for the Gateway even when it is unmated. Although the N-Type bulkhead connector on the Gateway provides ingress protection for the Gateway, the mating cable connector is likely not water proof and must be taped to provide ingress protection for the cable. TEKTELIC recommends taping with Scotch Wireless Weatherproofing Kit, WK-101. Follow the taping procedures outlined by the supplier of this tape system.

2.11 Proposition 65

WARNING: This product can expose you to chemicals including lead, beryllium & nickel, which is known to the State of California to cause cancer, birth defects or other reproductive harm. For more information, go to www.P65Warnings.ca.gov.

3 Radio Compliance Statements

Federal Communications Commission

This device complies with Part 15 of the FCC Rules. Operation is subject to the following two conditions:

1. This device may not cause harmful interference, and
2. This device must accept any interference received, including interference that may cause undesired operation.

Changes or modifications not expressly approved by the party responsible for compliance could void the user's authority to operate the equipment.

This equipment has been tested and found to comply with the limits for a Class B digital device, pursuant to Part 15 of the FCC Rules. These limits are designed to provide reasonable protection against harmful interference in a residential installation. This equipment generates uses and can radiate radio frequency energy and, if not installed and used in accordance with the instructions, may cause harmful interference to radio communications. However, there is no guarantee that interference will not occur in a particular installation. If this equipment does cause harmful interference to radio or television reception, which can be determined by turning the equipment off and on, the user is encouraged to try to correct the interference by one of the following measures:

1. Reorient or relocate the receiving antenna.
2. Increase the separation between the equipment and receiver.
3. Connect the equipment into an outlet on a circuit different from that to which the receiver is connected.
4. Consult the dealer or an experienced radio/TV technician for help.
5. To comply with FCC/IC RF exposure limits for general population / uncontrolled exposure, the antennas used for this transmitter must be installed to provide a separation distance of at least 30 cm from all persons and must not be co-located or operating in conjunction with any other antenna or transmitter. This product must be installed by professional trained RF technicians.

Industry Canada

This Device complies with Industry Canada License-exempt RSS standard(s). Operation is subject to the following two conditions:

1. This device may not cause interference, and
2. This device must accept any interference, including interference that may cause undesired operation of the device.

This radio transmitter 22504-T0005158 has been approved by Industry Canada to operate with the antenna types listed below with the maximum permissible gain indicated. Antenna types not included in

this list, having a gain greater than the maximum gain indicated for that type, are strictly prohibited for use with this device.

The required antenna impedance is 50 ohms.

Only omnidirectional type antennas with maximum gain of 3dBi can be used for the LoRa radios of this product if the cable insertion loss at 900 MHz is 0.5dB or more for 1 carrier operation at 28.5dBm or 2dB or more for 2 carrier operation at 30dBm total. Antenna(s) shall be installed to location providing a separation distance of at least 13.8 inches (35 cm) from any human body.

During product operation, always keep a separation distance of at least 13.8 inches (35 cm) from any connected antenna(s). Before servicing the product, the antenna(s) or cables, turn off the transmission function or the unit power if you have to get closer than the minimum separation distance. This product must be installed by professional trained RF technicians.

The 3G/4G modem antenna maximum allowed gain including cable loss shall be in accordance with the following table:

Technology	Band	Frequency (MHz)	Maximum Antenna Gain (dBi)
LTE	2	1850–1910	3.0
	4	1710–1755	6.0
	5	824–849	3.0
	13	777–787	6.0
	17	704–716	6.0
	25	1850–1915	3.0
UMTS	2	1850–1910	3.0
	4	1710–1755	6.0
	5	824–849	3.0
GSM	850	824–849	3.0
	1900	1850–1910	3.0
CDMA	BC0	824–849	3.0
	BC1	1850–1910	3.0
	BC10	817–824	3.0

Industrie Canada

Cet appareil est conforme aux normes RSS exemptes de licence d'Industrie Canada. Son fonctionnement est soumis aux deux conditions suivantes :

1. Cet appareil ne doit pas provoquer d'interférences, et
2. Cet appareil doit accepter toute interférence, y compris celles pouvant provoquer un mauvais fonctionnement de l'appareil.

Ce transmetteur radio 22504-T0005158 a été approuvé par Industrie Canada pour fonctionner avec les types d'antennes listés ci-dessous avec le gain maximum autorisé indiqué. Les types d'antennes non inclus dans cette liste, ayant un gain supérieur au gain maximum indiqué pour ce type, sont strictement interdits pour une utilisation avec cet appareil.

L'impédance requise de l'antenne est de 50 ohms.

Seules des antennes de type omnidirectionnel avec un gain maximum de 3 dBi peuvent être utilisées pour les radios LoRa de ce produit si la perte par insertion du câble à 900 MHz est de 0,5 dB ou plus pour une opération à 1 porteur à 28,5 dBm, ou de 2 dB ou plus pour une opération à 2 porteurs à 30 dBm au total. L(es) antenne(s) doivent être installées à un emplacement garantissant une distance de séparation d'au moins 35 cm (13,8 pouces) de tout corps humain.

Pendant le fonctionnement du produit, maintenez toujours une distance de séparation d'au moins 35 cm (13,8 pouces) par rapport à toute antenne connectée. Avant de réparer le produit, les antennes ou les câbles, éteignez la fonction de transmission ou l'alimentation de l'appareil si vous devez vous rapprocher de la distance de séparation minimale. Ce produit doit être installé par des techniciens RF professionnels formés.

Le gain maximal autorisé de l'antenne du modem 3G/4G, en incluant la perte de câble, doit être conforme au tableau suivant:

Technology	Band	Frequency (MHz)	Maximum Antenna Gain (dBi)
LTE	2	1850–1910	3.0
	4	1710–1755	6.0
	5	824–849	3.0
	13	777–787	6.0
	17	704–716	6.0
	25	1850–1915	3.0
UMTS	2	1850–1910	3.0
	4	1710–1755	6.0
	5	824–849	3.0
GSM	850	824–849	3.0
	1900	1850–1910	3.0
CDMA	BC0	824–849	3.0
	BC1	1850–1910	3.0
	BC10	817–824	3.0

Revision History

Revision	Issue Date	Status	Editor	Comments
0.2	Oct. 30, 2020	Obsolete	S. M.	Draft
0.3	Jan. 27, 2021	Obsolete	S. M.	Updated power consumption to reflect lower maximum based on 2W EIRP limit. Corrected ground lug size. Added a note that the second antenna port connector may or may not be present on the single antenna models.
0.4	Jan. 27, 2021	Obsolete	S. M.	Updated temperature classification
1.0	July 19, 2021	Obsolete	S. M.	Updated certification information
2.0	May 18, 2023	Obsolete	S. M.	Removed issue/rev number from the IECEx/ATEX certificate numbers
2.1	Oct 15, 2025	Obsolete	A. K.	New section added: Exposed Services
2.2	Jan 22, 2026	Released	A.K.	Updated Table 1 included Order codes, removed obsolete models Updated Table 3 included dimension excluding connector length Added French version of Radio compliance statements for Industry Canada.