

ORCA Industrial GPS Asset Tracker



User Guide

Document Number:	T0006279_UG
Document Version:	2
Product Code:	T0006129 (NA/EU 2X D-Cell Industrial GPS Asset Tracker)
Issue Date:	July 29, 2024

PROPRIETARY:

The information contained in this document is the property of TEKTELIC Communications Inc. Except as specifically authorized in writing by TEKTELIC, the holder of this document shall keep all information contained herein confidential, and shall protect the same in whole or in part from disclosure to all third parties.

Table of Contents

- 1 Product Description 3
 - 1.1 Overview..... 3
 - 1.2 Specifications..... 4
- 2 Installation 5
 - 2.1 Included Product and Installation Material 5
 - 2.2 Safety Precautions..... 5
 - 2.3 Unpacking and Inspection 5
 - 2.4 Commissioning 5
 - 2.5 Activation..... 6
 - 2.6 Mounting..... 6
 - 2.7 Default Configuration 7
 - 2.8 Reconfiguration 7
 - 2.9 LED Behaviour 8
 - 2.10 Battery Replacement..... 8
- 3 Functionality and Operation..... 9
 - 3.1 GNSS Operation..... 9
 - 3.2 Geofences..... 9
 - 3.3 Accelerometer Operation..... 9
 - 3.4 BLE Operation..... 9
- 4 Basic Downlinks 11
- 5 Device Configuration with ATLAS 13
- 6 LOCUS Application 15
 - 6.1 Description 15
 - 6.2 Operation principle 15
- 7 Data Converters 16
- 8 Compliance Statements..... 17
- Acronyms and Glossary..... 19
- Revision History..... 20

1 Product Description

1.1 Overview

ORCA is a multi-purpose LoRaWAN IoT industrial asset tracker using GNSS for outdoor tracking, and BLE for optional indoor tracking, equipped with an IoT MCU, LoRa radio and accelerometer. Table 1-1 presents the available ORCA model.

Table 1-1: Industrial GPS Asset Tracker Model

Product Code	Description	RF Region	Tx Band (MHz)	Rx Band (MHz)
T0006129	Industrial GPS Asset Tracker, 2X D-Cell	US915 EU868	923-928 863-870	902-915 863-870

The main features of the ORCA are the following:

- **GNSS:** Supports GPS, Galileo, GLONASS, BeiDou, QZSS, and SBAS.
- **BLE:** Bluetooth as an indoor positioning system.
- **Accelerometer:** High-sensitivity device that can measure any shock or movement events.

For more information on ORCA functionality please refer to [ORCA TRM](#).

Figure 1-1 illustrates the ORCA in the enclosure.

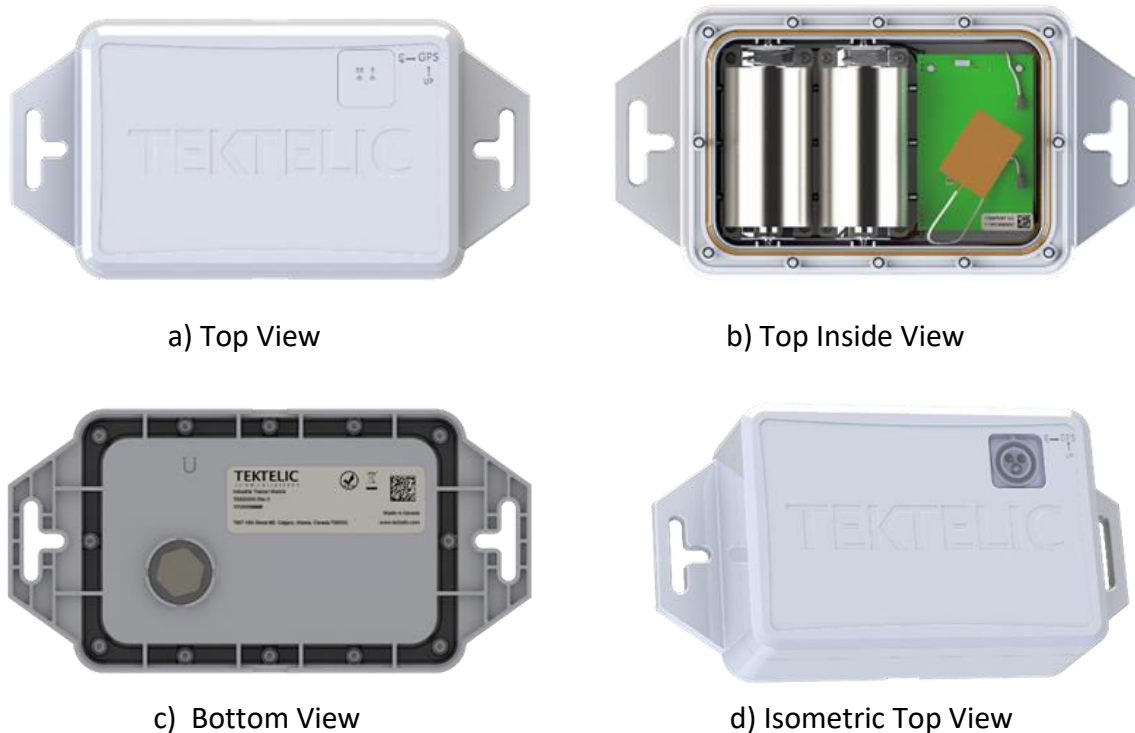

Figure 1-1: The Industrial GPS Asset Tracker module.

1.2 Specifications

The ORCA specifications are listed in Table 1-2.

Table 1-2: ORCA Specifications

Parameter	Specification
Use Environment	Industrial; Indoor/outdoor commercial/residential
Environmental Rating	IP67
Enclosure	Custom design by TEKTELIC
Humidity Vent	Mobi 3-FJ-S1-00-055 UV rated as part of other safety filings
Operating Temperature	-40°C to 70°C
Storage Temperature	-25°C to 55°C
Operating Relative Humidity	5%–95%, non-condensing
Storage Relative Humidity	10%–100%, non-condensing
Size	195 mm x 101 mm x 50 mm
Weight	300 g without battery; add 95 g per battery.
Power Source	Battery powered: 1x or 2x D-cell LTC (3.6 V DC) with reverse polarity protection
Network technology/Frequency band	US915, EU868
Air Interface	LoRa
Maximum Tx Power	22 dBm
Sensing Functions	GNSS, Accelerometer, BLE, Temperature, Battery Voltage Gauge
GNSS Features	Support of GPS/QZSS, GLONASS, Galileo, BeiDou Support of 3 concurrent GNSSs Data logging up to 3,000 entries Geofencing up to 4 circular geofences 2.5 m position accuracy TTFF: <ul style="list-style-type: none"> • 26 sec cold start • 1 sec hot start Sensitivity: <ul style="list-style-type: none"> • -164 dBm tracking and navigation • -148 dBm cold start • -157 dBm hot start
Accelerometer Sensitivity	Sample rate: 1 Hz, 10 Hz, 25 Hz, 50 Hz, 100 Hz, 200 Hz, 400 Hz Measurement range: $\pm 2 g$, $\pm 4 g$, $\pm 8 g$, $\pm 16 g$ Precision: 16 mg, 32 mg, 64 mg, 192 mg
Bluetooth Compatibility	BLE based on Bluetooth 5.0
BLE Sensitivity (0.1% BER)	125 kbps: -103 dBm 500 kbps: -98 dBm 2 Mbps: -91 dBm
Temperature Measurement Accuracy (non-ambient)	$< \pm 10^{\circ}\text{C}$
LED	Green: Joining the network and LoRa Rx activity Red: LoRa Tx activity
Battery Fuel Gauge Features	2x gauges for up to 2 LTC batteries Measuring battery voltage
Battery Lifetime	2.4 years per battery (with default settings)

2 Installation

2.1 Included Product and Installation Material

The following items are shipped:

- ORCA Industrial GPS Asset Tracker with 2 D-cell LTC batteries installed

2.2 Safety Precautions

The following safety precautions should be observed:

- Use only LTC cells.
- All installation practices must be in accordance with the local and national electrical codes.

2.3 Unpacking and Inspection

The following should be considered during the unpacking of a new ORCA:

- Inspect the shipping carton and report any significant damage to TEKTELIC.
- Unpacking should be conducted in a clean and dry location.
- Do not discard the shipping box or inserts as they will be required if a unit is returned for repair or re-configuration.

2.4 Commissioning

Each sensor has a set of information that must be entered into the network server before activation. For instructions, please refer to the Quick Start Guide in the box (available in the [Knowledge Base](#)).

You can find the commissioning keys inside the box. If you don't have the box, please raise a ticket in our support portal and provide the Tcode and serial number on the tag placed on the device



Figure 2-1: ORCA Commissioning Keys

2.5 Activation

The ORCA is shipped in a state of DEEP SLEEP and needs to be activated by the magnet.

NOTE: To activate ORCA you will need any magnet almost as strong as Standex-Meder M4, M5, or M13. Enclosure does not need to get opened for activation.

To activate the device:

1. Briefly place the magnet against the enclosure at the magnetic sign as shown in Figure 2-2 for **about 5 seconds** and take away.
2. Sensor activation will be displayed by **GREEN** and **RED** LEDs briefly turning on.

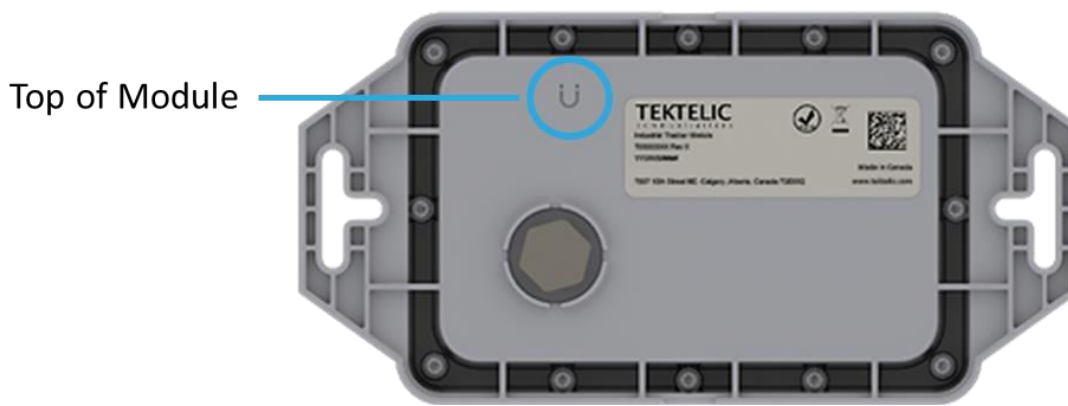

Figure 2-2: The ORCA magnetic activation site.

To return to DEEP SLEEP:

- open the enclosure and press the internal sleep button (SW2) located visibly on top of the ORCA PCBA

NOTE: ORCA doesn't go to DEEP SLEEP when batteries are replaced.

To reactivate the device there are 2 options:

1. Use magnet activation instruction
2. Remove and reinsert the batteries

NOTE: Save your desired configuration to the ORCA flash before powering off, putting to DEEP SLEEP, or resetting as all unsaved configurations will be lost during these processes.

2.6 Mounting

On either side of the enclosure there are two mounting holes, see Figure 2-. These mounting holes can be used to screw the device with ropes, zip ties or M3 screws (not provided with the device).

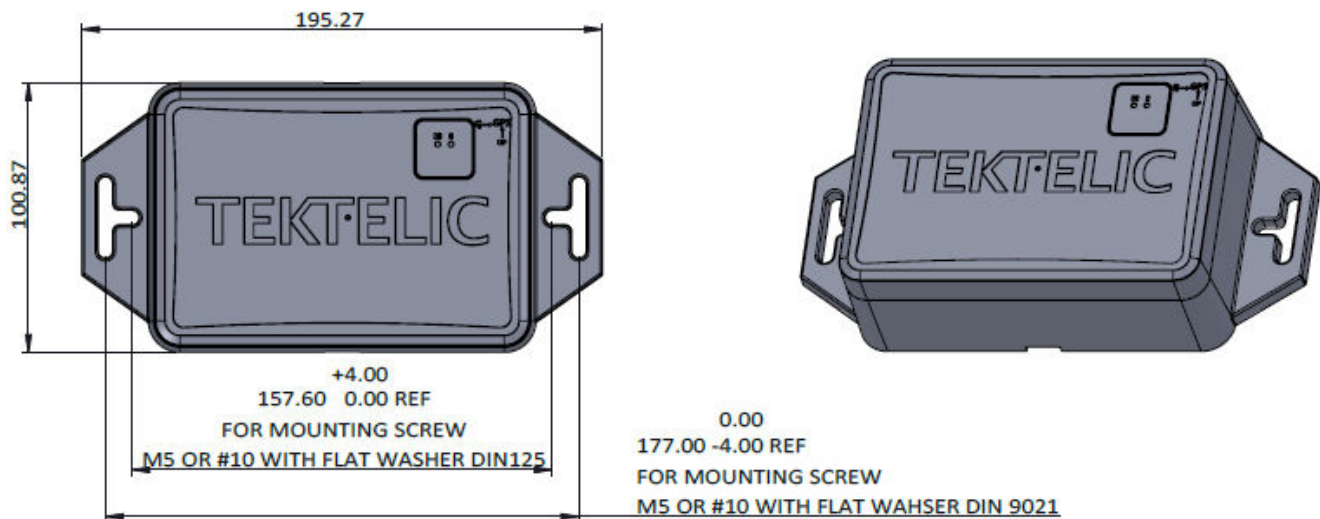

Figure 2-3: The mounting holes and enclosure screw holes.

The mounting surface must be capable of holding > 2 kg (4.5 lbs).

2.7 Default Configuration

The default configuration on the ORCA is described in Table 2-1.

Table 2-1: ORCA Default Reporting Behavior

Report	Report Type	Periodicity
Battery voltage	Periodic	1 day
UTC and GNSS position fix	Periodic	1 hour
	Event-Based	Every time the accelerometer threshold is breached (when motion begins) Every time the accelerometer grace period elapses (when motion stops)
Acceleration alarm	Event-Based	Every time the accelerometer threshold is breached (when motion begins)
		Every time the accelerometer grace period elapses (when motion stops)
Discovered BLE devices (up to 8) when in STILLNESS or MOBILITY	Periodic	Disabled
Discovered BLE devices (up to 8) when in DEFAULT	Periodic	1 hour
FSM State	Event-Based	Every time the magnet is used to force UL

2.8 Reconfiguration

The ORCA supports a full range of OTA configuration options. Specific technical details are available in the [ORCA TRM](#). All configuration commands need to be sent OTA during a ORCA's DL windows.

2.9 LED Behaviour

The ORCA is equipped with two on-board LEDs: **GREEN** and **RED**. They are visible through the enclosure at the location shown in Figure 2-4.



Figure 2-4: The ORCA Enclosure Top View Showing Location of LEDs

LED behavior summarized in Table 2-2.

Table 2-2: ORCA LED Behavior

Behavior	Meaning
Both LEDs briefly on, then off. System (Green) blinks briefly (<1 sec).	All health checks passed.
Both LEDs briefly on, then off. LoRa (Red) blinks briefly (<1 sec).	Health check failed. Consider replacing batteries or moving to suitable temperature range.
Rapid green blinking occurs when attempting to join	ORCA is attempting to join a network.
LoRa (Red) blinks during LoRa Tx activity (transmitting packets)	Indicates LoRa activity during normal operation.

2.10 Battery Replacement

To replace ORCA batteries:

1. Use a T10 screwdriver to remove the 12 enclosure Torx Head screws from the bottom. Keep the silicone cover gasket safe.
2. Replace batteries using D-size, 3.6 V, LTC batteries. Recommended options include Tadiran TL-4930/S or TL-5930/S, Xeno Energy XL-205F STD, or Saft LS33600.
3. Replace the cover and ensure the gasket is correctly seated. Tighten the 12 cover screws to 2.5 lbf-in (30 N-cm).

3 Functionality and Operation

3.1 GNSS Operation

Global Navigation Satellite System (GNSS) provides autonomous geopositioning with global coverage. The GNSSs that ORCA supports are GPS, GLONASS, Galileo, BeiDou, QZSS, and SBAS. The primary purpose of the GNSS receiver is to conduct GNSS searches, periodically or at interrupt, to obtain geopositioning information. The ORCA is also equipped with flash storage for logging the historical geopositioning data, which can be retrieved and forwarded through LoRaWAN ULs upon request. The GNSS receiver can be powered off/on to tune power usage (battery life) for end-user applications.

GNSS Data Values	GNSS Diagnostics Values
<ul style="list-style-type: none">• UTC*• Position coordinates (latitude, longitude, altitude) *• Ground speed• Geofence statuses	<ul style="list-style-type: none">• Number of visible satellites• Average satellite SNR• Fix type• Time-To-Fix (TTF)• Most recent log entry number• Ghost error count

*Enabled to be reported by default.

Table 3-1: Optional Values for GNSS Reporting

3.2 Geofences

The ORCA supports setting up to 4 geofences. Geofences are virtual perimeters that define the boundary between 2 areas of interest: inside the geofence or outside the geofence. These are useful for defining and monitoring special geographical regions by allowing the ORCA to send status information about whether it is located inside or outside of a geofence, or if the status is unknown. Each geofence area is a circle and is defined by the latitude and longitude of its center and its radius. By default, all geofences are inactive.

3.3 Accelerometer Operation

The accelerometer in the ORCA can be disabled or enabled and supports both periodic-based and event-based reporting. The accelerometer is enabled by default. When enabled, it samples at a configurable rate as a background process throughout all normal operation after joined to the network.

3.4 BLE Operation

The ORCA supports BLE of Bluetooth 5.0 mainly aimed to be used for indoor tracking. To use this function a BLE network and localization application must be established. Tektelic [LOCUS application](#) can be used as a part of ORCA tracking solution.

The BLE function of the ORCA is Rx only; the ORCA only scans and does not advertise, which means it is not discoverable by other BLE-capable devices. During each scan, other advertising BLE devices can be discovered. Each discovered device has its data (MAC address and the RSSI of the advertisement packet) saved by the ORCA to then be reported in an UL. This UL is normally reported immediately after the scan concludes but may be delayed due to duty cycle limitations. If a new BLE scan occurs before the results of the previous scan have been sent, the old scan results will be discarded. The BLE scan can be disabled entirely or enabled at any time. BLE scans are performed periodically with a configurable scan period.

4 Basic Downlinks

ORCA use a "tick" system for reporting data. Generally, the sensor will report most important data every tick. A tick can be measured in seconds.

There are two sets of settings that must be configured in conjunction - "Core reporting tick in seconds" and "Ticks per [data/report]".

"Core reporting tick in seconds" will determine the interval between ticks. For example, you may set it to 60 seconds or 180 seconds (3 minutes) for each tick.

"Ticks per [data/report]" determines how many ticks it will take before the sensor reports any data. For example, if you set "Ticks per Battery report" to 2, it will take 2 ticks before the sensor reports battery data.

To Change The Core Report To Every Minute

With LeapX application (you can get it on [Google Play](#) or [App Store](#)): write number 1 in the field minutes between reports, then click on save changes.

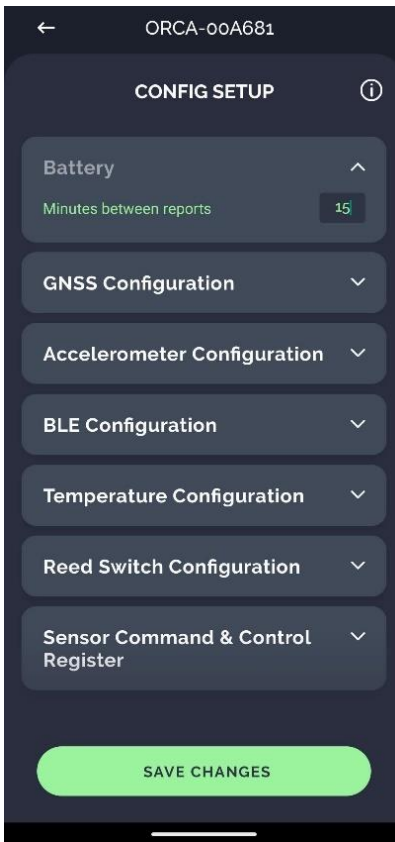

Figure 4-1 LeapX application

With ATLAS: check the box for Core report tick in seconds and ticks between ambient temperature reports. Write the values shown in the Figure 4-2 and click send.

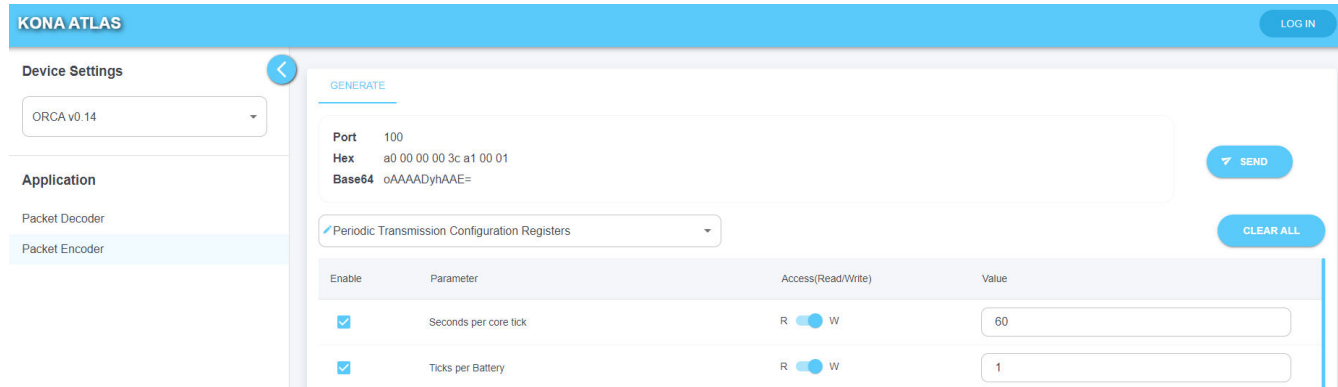

Figure 4-2 ATLAS

Examples Of Uplinks

- 0x 00 95 00 00 71 02 44 00 46 03 3E
 - 0x 00 95 (Fix Status):
 - (0x 00) = No valid UTC and position fix available
 - 0x 00 71 (Acceleration Vector):
 - X-Axis Acceleration = (0x 02 44) × 0.001 g = 0.58 g
 - Y-Axis Acceleration = (0x 00 46) × 0.001 g = 0.07 g
 - Z-Axis Acceleration = (0x 03 3E) × 0.001 g = 0.83 g

- 0x 00 88 3E 50 B0 BC 02 2D 60 08 2A
 - 0x 00 88 (Position Coordinates):
 - Latitude = (0x 3E 50 B0) × 0.0000125° = 51.0486°
 - Longitude = (0x BC 02 2D 60) × 0.0000001° = 114.0708°
 - Altitude = (0x 08 2A) × 0.5 m = 1045 m

5 Device Configuration with ATLAS

To perform more configuration or read the data of device you can use TEKTELIC's complementary service, [ATLAS](http://www.atlas.tektelic.com) at www.atlas.tektelic.com.

There are two ways to access ATLAS:

1) Using in Offline mode

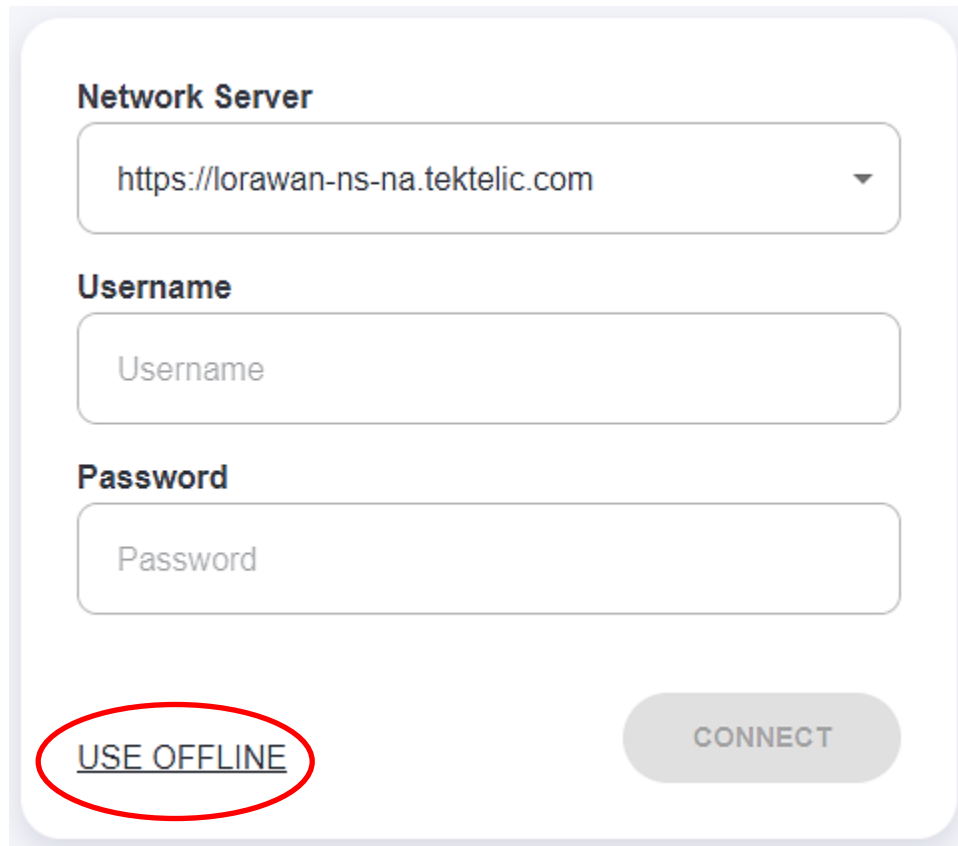

The screenshot shows a login form with the following fields and elements:

- Network Server:** A dropdown menu with the value "https://lorawan-ns-na.tektelic.com".
- Username:** A text input field with the placeholder text "Username".
- Password:** A text input field with the placeholder text "Password".
- USE OFFLINE:** A button with the text "USE OFFLINE" circled in red.
- CONNECT:** A button with the text "CONNECT".

Figure 5-1 Login as offline mode

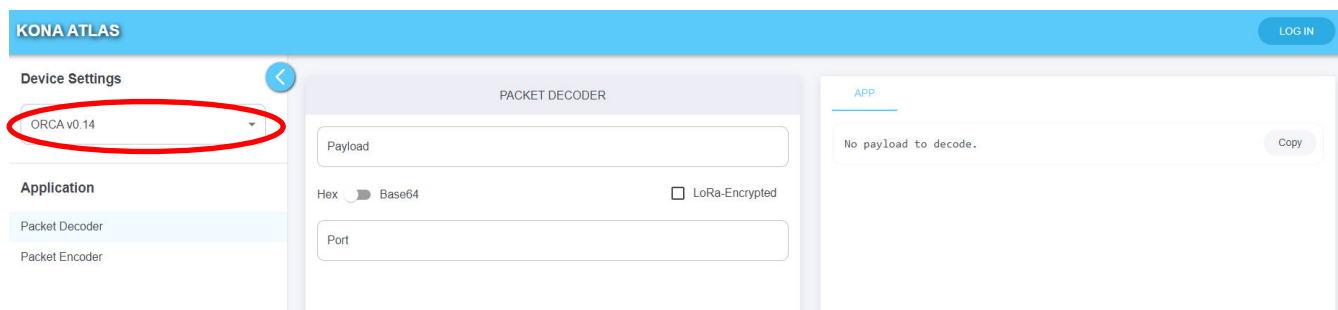

The screenshot shows the ATLAS interface with the following elements:

- KONA ATLAS:** Header bar with a "LOG IN" button.
- Device Settings:** A sidebar menu with a dropdown menu showing "ORCA v0.14" circled in red.
- Application:** A list of applications including "Packet Decoder" and "Packet Encoder".
- PACKET DECODER:** A section with a "Payload" input field, a "Hex" radio button (selected), a "Base64" radio button, a "LoRa-Encrypted" checkbox, and a "Port" input field.
- APP:** A section with a "Copy" button and the text "No payload to decode."

Figure 5-2 Select ORCA decoder

2) with your TEKTELIC Network Server Credentials

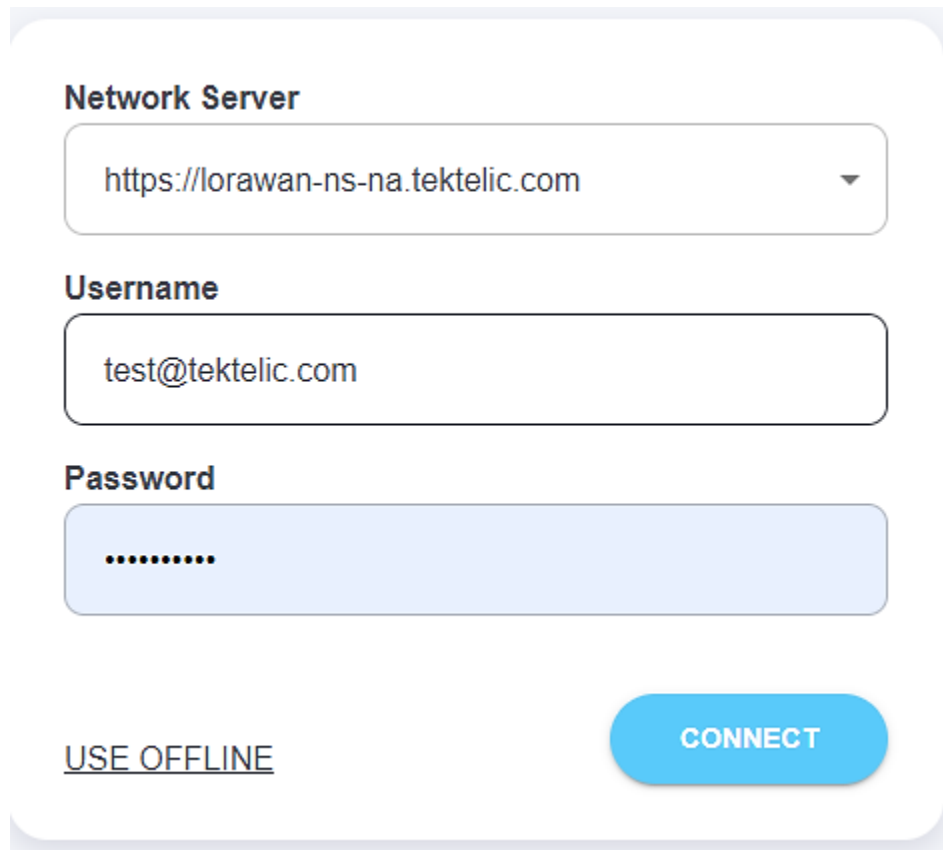

The image shows a login form with three input fields and two buttons. The first field is labeled "Network Server" and contains the URL "https://lorawan-ns-na.tektelic.com". The second field is labeled "Username" and contains "test@tektelic.com". The third field is labeled "Password" and contains a series of dots. Below the fields are two buttons: "USE OFFLINE" and "CONNECT".

Figure 5-3 Login with Network server credentials

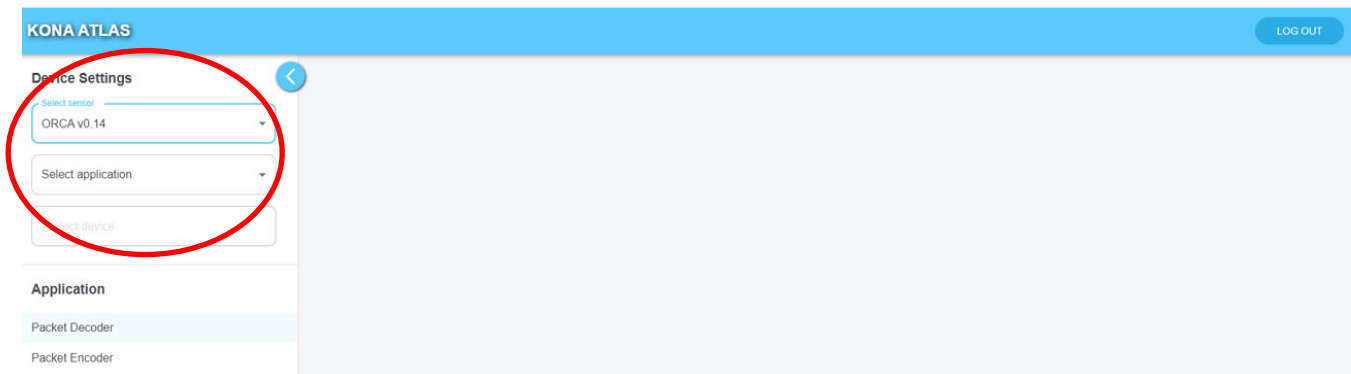

The image is a screenshot of the KONA ATLAS web interface. The top navigation bar is blue and contains the text "KONA ATLAS" on the left and "LOG OUT" on the right. Below the navigation bar is a "Device Settings" section. This section contains three dropdown menus: "Select sensor" (with "ORCA v0.14" selected), "Select application", and "Select device". A red circle highlights these three dropdown menus. Below the "Device Settings" section is an "Application" section with two options: "Packet Decoder" (highlighted in light blue) and "Packet Encoder".

Figure 5-4 Select ORCA Decoder, application and the device

For more information follow this link <https://knowledgehub.tektelic.com/kona-atlas>

6 LOCUS Application

6.1 Description

Locus is an application to track and monitor all assets in your network, including indoor, outdoor, and hazardous location asset tracking. Assets can be tracked across entire campuses, multiple buildings, and floors. For more detail about Locus please visit [Locus Application Documentation](#)

Application capabilities:

- Self managed floor plan/map loading
- User management – permission levels
- Geofencing & alerts
- API to customer database integration
- Support of multiple campuses, buildings & floors
- Device management/battery status
- Integrated to enterprise SAP

6.2 Operation principle

Asset tag localization uses RSSI multilateration. The location is determined by the signal strength reported by the BLE beacon in relation to the asset tag, providing precise location accuracy (2-5m).

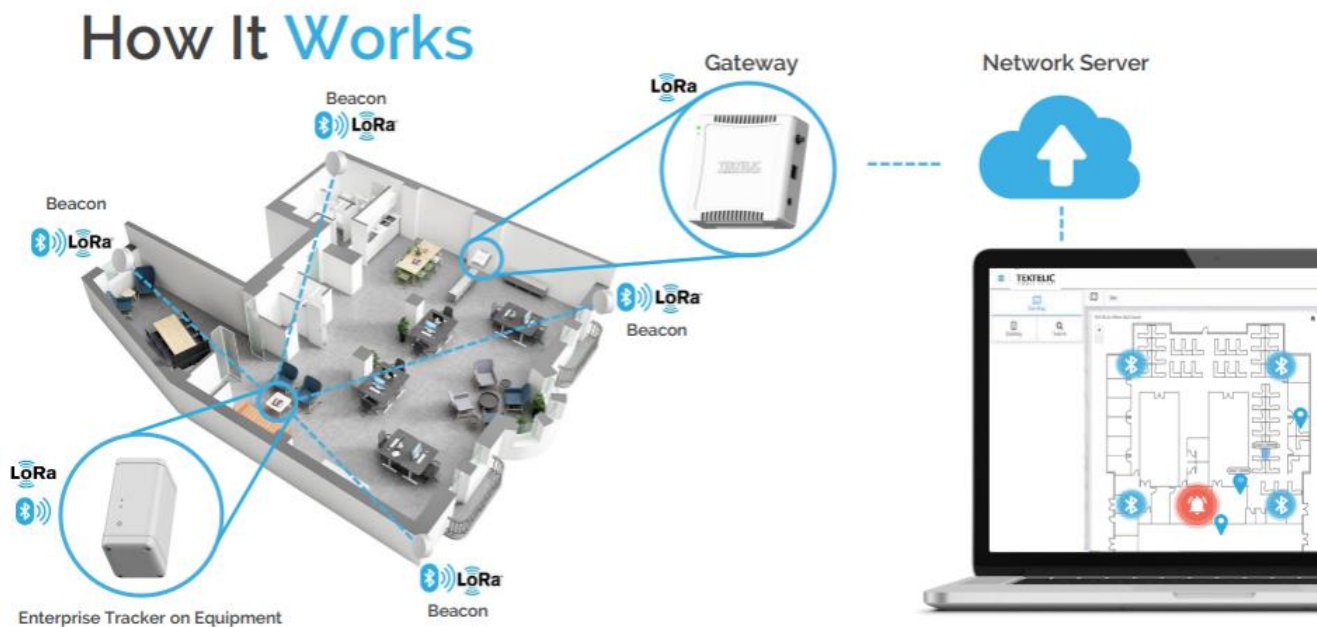

7 Data Converters

Please follow this link: <https://github.com/TektelicCommunications/data-converters/tree/master> for the data converters that are to be used on TEKTELIC & other Network Server for TEKTELIC Sensors.

These data converters can be used as a reference for other platforms.

TEKTELIC's data converters conform to the LoRa Alliance Payload Codec Specification and can be used with any 3rd party Network Server / Application Server that supports this specification.

<https://resources.lora-alliance.org/technical-specifications/ts013-1-0-0-payload-codec-api>

8 Compliance Statements

Federal Communications Commission:

This device complies with Part 15 of the FCC Rules. Operation is subject to the following two conditions:

1. This device may not cause harmful interference, and
2. This device must accept any interference received, including interference that may cause undesired operation.

To comply with FCC exposure limits for general population / uncontrolled exposure, this device should be installed at a distance of 20 cm from all persons and must not be co-located or operating in conjunction with any other transmitter.

Changes or modifications not expressly approved by the party responsible for compliance could void the user's authority to operate the equipment. This equipment has been tested and found to comply with the limits for a Class B digital device, pursuant to Part 15 of the FCC Rules. These limits are designed to provide reasonable protection against harmful interference in a residential installation. This equipment generates uses and can radiate radio frequency energy and, if not installed and used in accordance with the instructions, may cause harmful interference to radio communications. However, there is no guarantee that interference will not occur in a particular installation. If this equipment does cause harmful interference to radio or television reception, which can be determined by turning the equipment off and on, the user is encouraged to try to correct the interference by one of the following measures:

- Reorient or relocate the receiving antenna.
- Increase the separation between the equipment and receiver.
- Connect the equipment into an outlet on a circuit different from that to which the receiver is connected.
- Consult the dealer or an experienced radio/TV technician for help.

Innovation, Science and Economic Development Canada (Industry Canada):

This device contains licence-exempt transmitter(s)/receiver(s) that comply with Innovation, Science and Economic Development Canada's licence-exempt RSS(s). Operation is subject to the following two conditions:

- (1) This device may not cause interference, and
- (2) This device must accept any interference, including interference that may cause undesired operation of the device.

This device should be installed and operated with minimum distance 0.2 m from human body.

L'émetteur/récepteur exempt de licence contenu dans le présent appareil est conforme aux CNR d'Innovation, Sciences et Développement économique Canada applicables aux appareils radio exempts de licence. L'exploitation est autorisée aux deux conditions suivantes:

- (1) L'appareil ne doit pas produire de brouillage.
- (2) L'appareil doit accepter tout brouillage radioélectrique subi, même si le brouillage est susceptible d'en compromettre le fonctionnement.

Cet appareil doit être installé et utilisé à une distance minimale de 0.2 m du corps humain.

California Proposition 65:

 **WARNING:** This product can expose you to chemicals including lead, nickel, and carbon black, which are known to the State of California to cause cancer, birth defects or other reproductive harm. For more information, go to www.P65Warnings.ca.gov.

Acronyms and Glossary

BeiDou	BeiDou Navigation Satellite System (BDS), a Chinese satellite navigation system
BER	bit error rate
BLE	Bluetooth Low Energy
bps	bits per second
DL	downlink
EIRP	equivalent isotropically radiated power
FCC	Federal Communications Commission
GLONASS	GLObal NAVigation Satellite System
GNSS	Global Navigation Satellite System
GPS	Global Positioning System
IoT	Internet of Things
IP	Ingress Protection
LED	light emitting diode
LoRa	a patented “long-range” IoT technology acquired by Semtech
LoRaWAN	LoRa wide area network (a network protocol based on LoRa)
LTC	lithium thionyl chloride (chemistry of LTC batteries)
MCU	microcontroller unit
NS	network server
OTA	over the air
PCBA	printed circuit board assembly
QZSS	Quasi-Zenith Satellite System
RF	radio frequency
RSS	Radio Standards Specifications
RSSI	received signal strength indicator
Rx	receiver, receive
SBAS	Satellite-Based Augmentation System
Tracker	any variant of the Industrial GPS Asset Tracker
TTF	time to first fix
TRM	technical reference manual
Tx	transmitter, transmit
UG	user guide (this document)
UTC	Coordinated Universal Time
UV	ultraviolet
ver.	version

Revision History

Revision	Issue Date	Editor	Comments
0.1	May 31, 2019	Emma Tholl	<ul style="list-style-type: none"> Initial draft.
0.2	Sep 23, 2019	Reza Nikjah	<ul style="list-style-type: none"> Added the resetting, awakening, powering off, and putting into DEEP SLEEP procedures. It is assumed now that the modules are shipped in closed IP67 enclosures with already installed and engaged batteries. Added Acronyms and Glossary section Completed the specification table Edited the compliance statements Made some general, minor edits
0.3	Oct 15, 2019	Conor Karperien	<ul style="list-style-type: none"> Updated design
1.0	Nov 5, 2019	Reza Nikjah	<ul style="list-style-type: none"> Released
1.1	Nov 13, 2019	Reza Nikjah	<ul style="list-style-type: none"> Removed Tracker variant models not yet available
1.2	Nov 19, 2019	Reza Nikjah	<ul style="list-style-type: none"> Consistently named the product the Industrial GPS Asset Tracker
2	29 July 2024	Marharyta Yuzefovych	<ul style="list-style-type: none"> User-friendly format